



US00D544564S

(12) **United States Design Patent**  
**Swan**

(10) **Patent No.:** **US D544,564 S**

(45) **Date of Patent:** **\*\* Jun. 12, 2007**

(54) **CLAMP MOUNTED AND GUARD ASSEMBLY**

(76) Inventor: **Richard E. Swan**, 171 West St., East  
Bridgewater, MA (US) 02333

(\*\*) Term: **14 Years**

(21) Appl. No.: **29/237,440**

(22) Filed: **Aug. 31, 2005**

(51) **LOC (8) Cl.** ..... **22-01**

(52) **U.S. Cl.** ..... **D22/108**

(58) **Field of Classification Search** ..... D22/100,  
D22/108, 109, 110, 199; 42/11, 113, 116,  
42/119, 124, 125, 127, 90, 145, 128, 72, 106,  
42/114, 85, 75.02, 71.01; 248/205.1, 201

See application file for complete search history.

(56) **References Cited**

**U.S. PATENT DOCUMENTS**

1,115,979 A	11/1914	Sillix	
2,775,166 A	12/1956	Janson	
2,844,710 A	7/1958	Zinsser	
3,276,377 A	10/1966	Bell	
3,611,606 A	10/1971	Sefried et al.	
4,027,414 A	6/1977	Felix	42/1 ST
4,085,511 A	4/1978	Kovac	33/250
4,205,473 A	6/1980	Wilson	42/1 ST
4,249,315 A	2/1981	Hopson, III	33/250
4,485,871 A	12/1984	Davis	166/266
5,010,676 A	4/1991	Kennedy	42/71.1
5,062,346 A	11/1991	Greve Hansen et al.	89/14.1
5,097,614 A	3/1992	Strong	42/76.01
5,123,329 A	6/1992	Irwin	89/161
5,142,806 A	9/1992	Swan	42/101
5,343,650 A	9/1994	Swan	42/100
5,533,929 A	7/1996	Attridge, Jr.	454/369

6,490,822 B1	12/2002	Swan	42/71.01
6,508,027 B1 *	1/2003	Kim	42/124
6,606,813 B1 *	8/2003	Squire et al.	42/90
6,618,976 B1 *	9/2003	Swan	42/114
6,779,288 B1 *	8/2004	Kim	42/72
6,895,708 B2 *	5/2005	Kim et al.	42/72
D510,120 S *	9/2005	Ding	D22/108
D513,298 S *	12/2005	Ding	D22/110
D513,299 S *	12/2005	Ding	D22/110
D513,633 S *	1/2006	Ding	D22/110

\* cited by examiner

*Primary Examiner*—Ian Simmons

*Assistant Examiner*—Melanie Levy

(74) *Attorney, Agent, or Firm*—Barlow, Josephs & Holmes,  
Ltd.

(57) **CLAIM**

The ornamental design for clamp mounted hand guard assembly, as shown and described.

**DESCRIPTION**

FIG. 1 is a perspective view of a clamp mounted hand guard assembly, showing my new design;

FIG. 2 is a top plan view thereof;

FIG. 3 is a side view thereof, both left and right sides being mirror images and appearing the same;

FIG. 4 is a bottom view thereof;

FIG. 5 is a rear view thereof;

FIG. 6 is a front rear view thereof; and,

FIG. 7 is and exploded an exploded perspective view thereof.

**1 Claim, 6 Drawing Sheets**

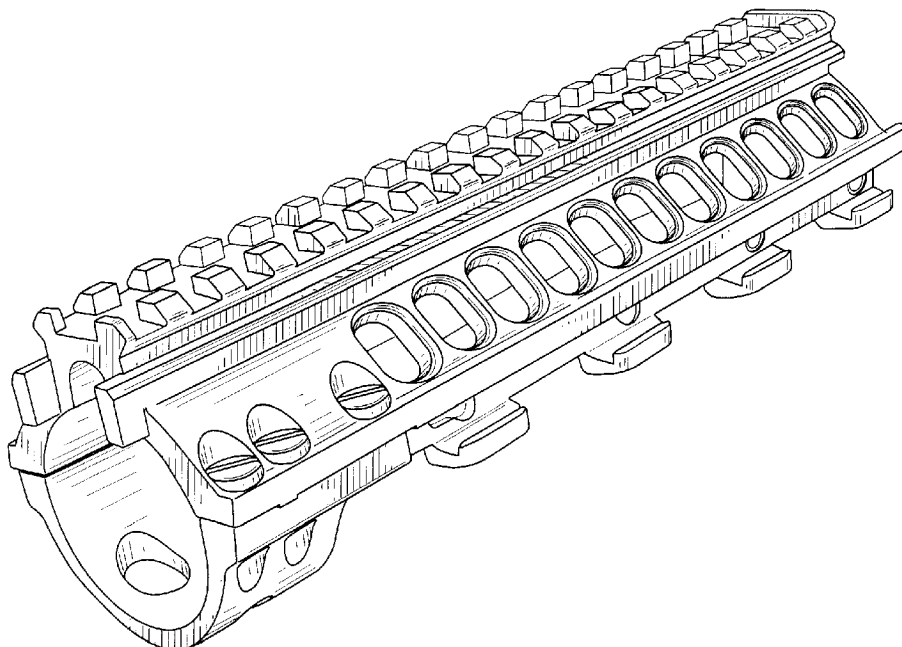

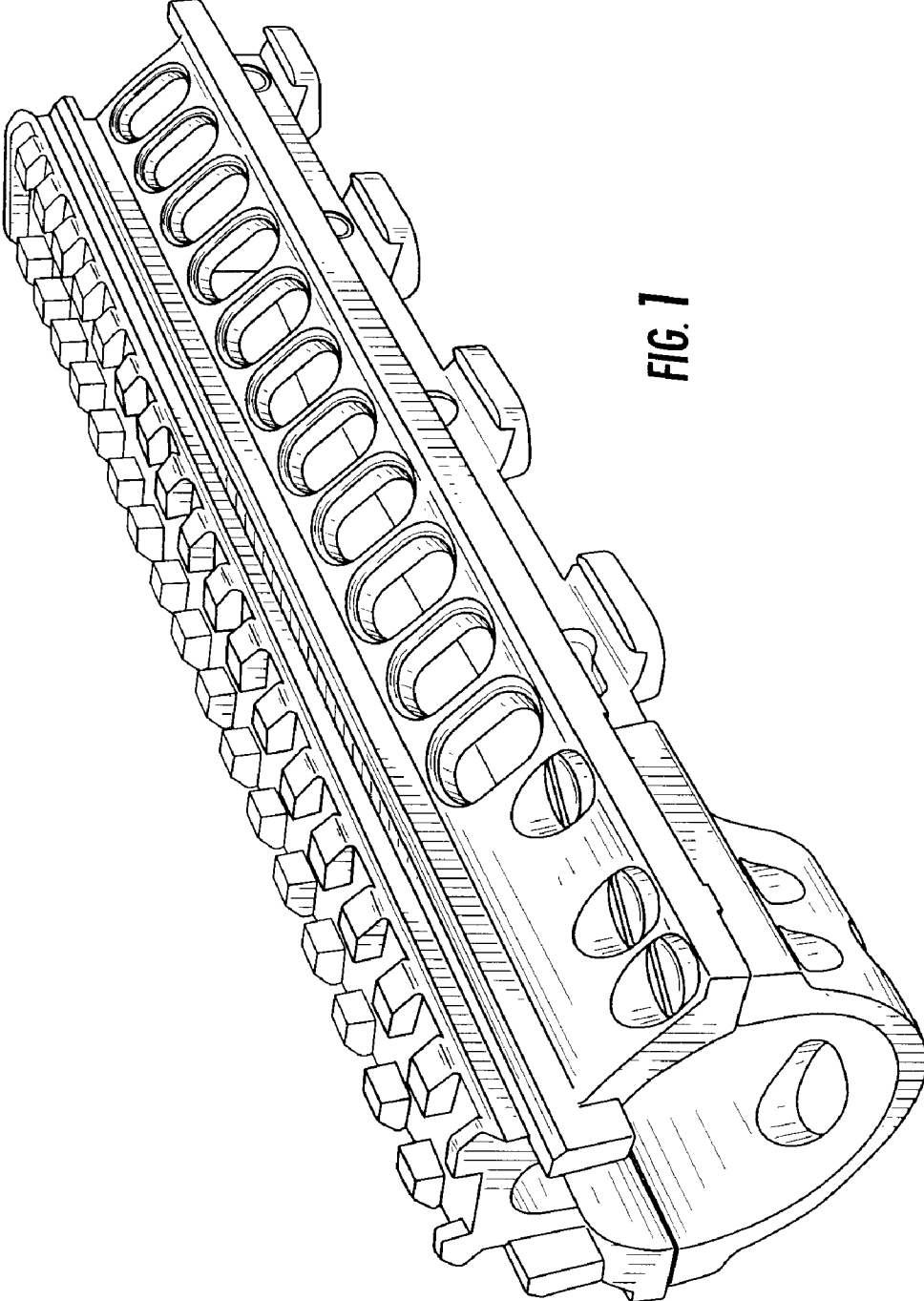

FIG. 1

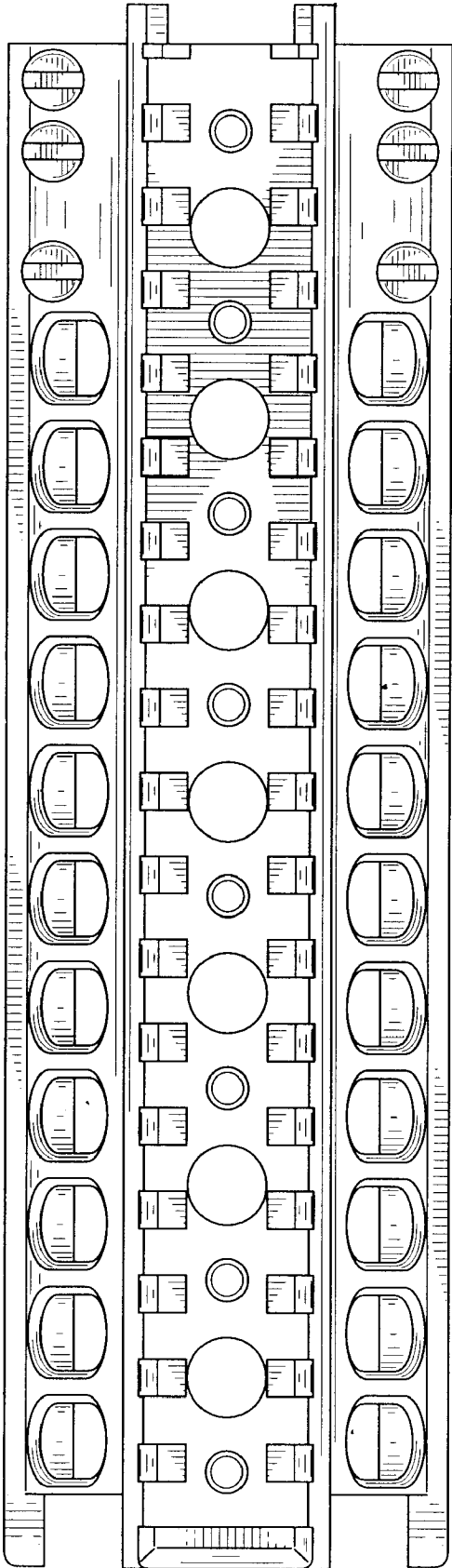

FIG. 2

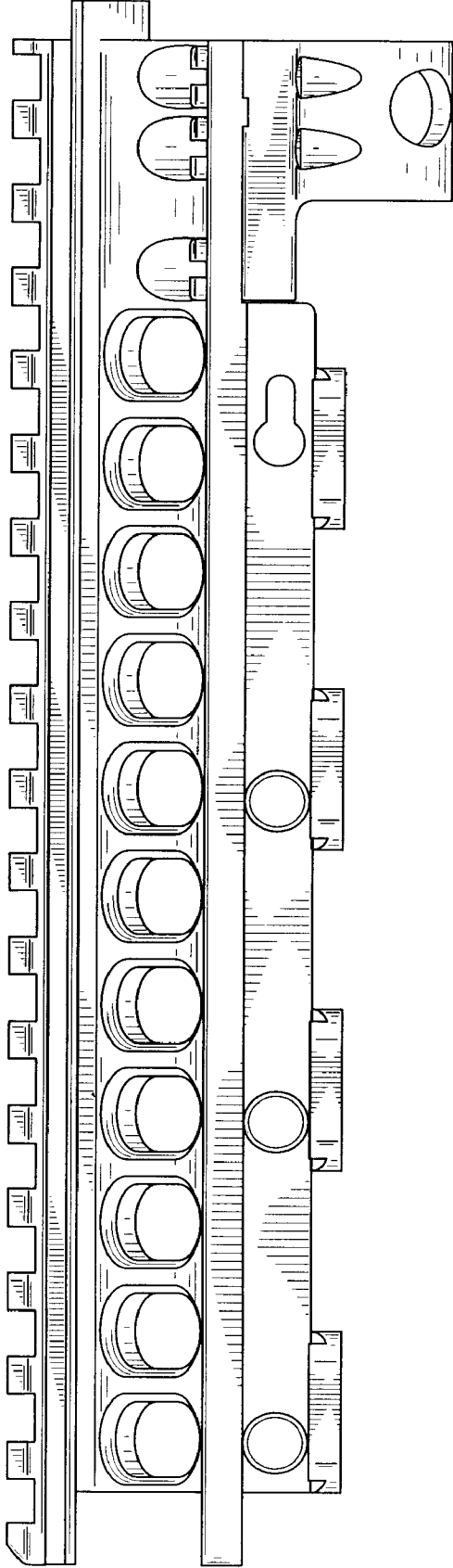

FIG. 3

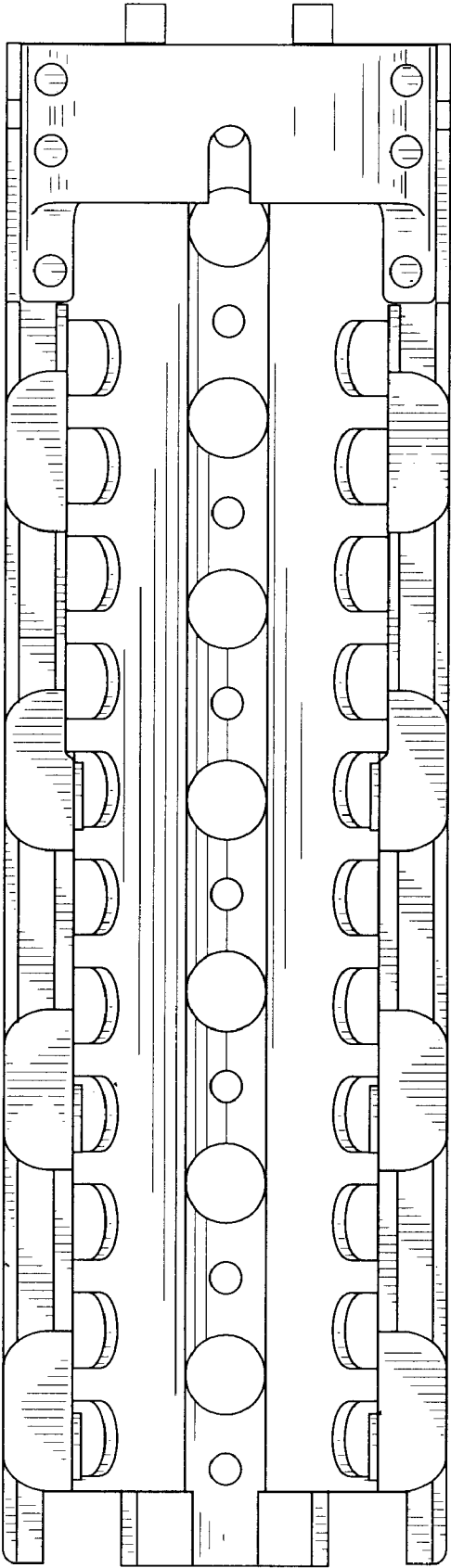
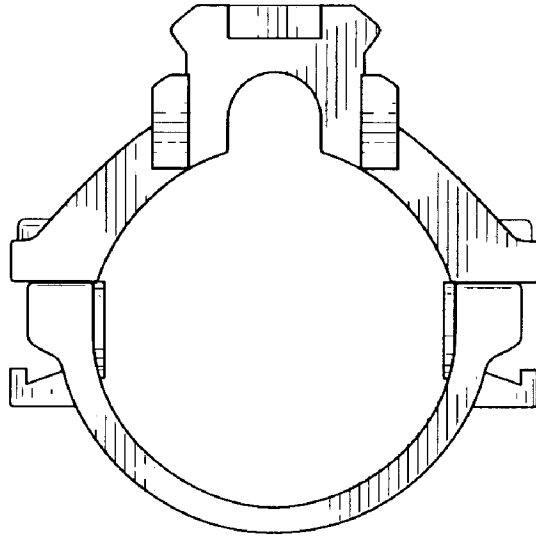
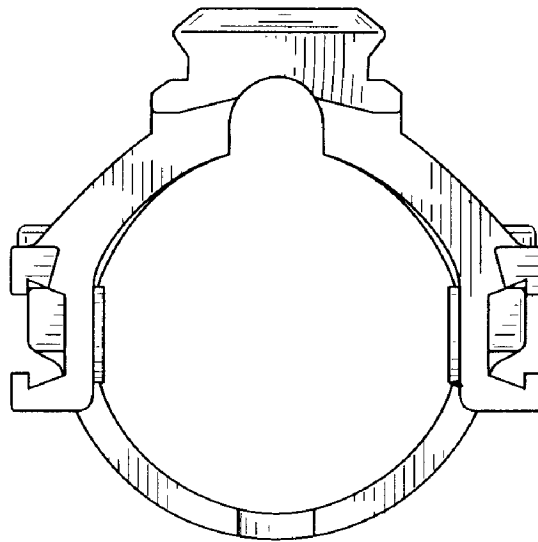

FIG. 4



**FIG. 5**



**FIG. 6**

